



SMITH DR-A473

Smith is a low glare compact luminaire for lower level and more precise accenting. Available as an adjustable downlight with a selection of narrower beam settings they are perfect for highlighting key elements of your design.

Energy efficiency is a key component of our product focus and Smith will ensure significant energy savings over traditional solutions. Phase dimmable with 0-10V and DALI available upon request.

Available in fixed and adjustable with warm dimming and shape adjusting optical accessories.

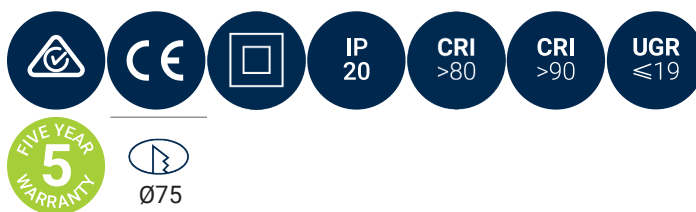
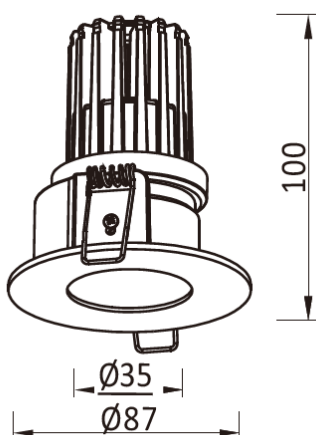

Model	Source Power (W)	System Power (W)	Source Lumen (Lm) (CRI>80, 3000K)	System Lumen (Lm) / Beam Angle (CRI>80, 3000K)			
				Narrow (16°/15°)	Narrow (23°/21°)	Medium (31°/32°)	Medium (36°)
DR-A473-A	7	9	745	283	543	546	375
DR-A473-B	12	14	1660	439	872	1037	666

CRI	CCT	Material	LED Lifetime	Colour	Voltage	Dimming
>80/>90	3000K/4000K	Aluminium	50,000 hrs (L70)	BK / WH	220-240V	Available on request



Accessories

(available on request)

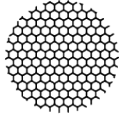

Honeycomb Lens



Anti-glare

Photometrics

(standard beam angles, alternative available on request)

